

General Awareness

S1. Ans.(b)

Sol. Global financial services major HSBC inaugurated its International Banking Unit (IBU) branch at GIFT City near Gandhinagar city in Gujarat.

S2. Ans.(a)

Sol. The theme guiding Holocaust remembrance and education in 2021 is "Facing the Aftermath: Recovery and Reconstitution after the Holocaust".

S3. Ans.(c)

Sol. Board of Directors of Kerala-based Dhanlaxmi Bank have given approval to appoint Shivan J K as managing director and CEO of the Bank.

S4. Ans.(e)

Sol. Union Minister Nirmala Sitharaman virtually inaugurated the Chennai Bench of the National Company Law Appellate Tribunal (NCLAT).

S5. Ans.(d)

Sol. Former India goalkeeper Prasanta Dora, who also played for the big three clubs of Kolkata football, passed away.

S6. Ans.(e)

Sol. Maharashtra Chief Minister Uddhav Thackeray launched a 'jail tourism' initiative of the state government from Pune's Yerawada prison, in a move to help students learn about historical experiences.

S7. Ans.(a)

Sol. India has announced a pledge of USD 150,000 to the United Nations Peacebuilding Fund (PBF) for the year 2021 to support the activities and programs this year.

S8. Ans.(b)

Sol. Accenture retained the title of world's most valuable and strongest IT services brand with record brand value of USD 26 billion.

S9. Ans.(a)

Sol. The International Energy Agency (IEA), which has its headquarters in Paris.

S10. Ans.(d)

Sol. Sunil Arora took charge as Chief Election Commissioner of India on 2nd December 2018.

S11. Ans.(b)

Sol. Kaja Kallas, the leader of the Reform Party will become Estonia's first female prime minister.

S12. Ans.(c)

Sol. The Office of the Chief Electoral Officer, Meghalaya was selected for a Special Award for Information Technology applications in Elections by the Election Commission of India (ECI), in the National Best Electoral Practices Awards-2020.

S13. Ans.(e)

Sol. This year International Customs Day theme: "Customs bolstering Recovery, Renewal and Resilience".

S14. Ans.(c)

Sol. Vittorio Storaro has been conferred with the Lifetime Achievement Award at 51st IFFI held in Goa.

S15. Ans.(c)

Sol. Gujarat is the headquarters of International Financial Services Centres Authority.

S16. Ans.(d)

Sol. The Ram Temple tableau of Uttar Pradesh that was on display during the Republic Day 2021 has bagged the first prize among all tableaux.

S17. Ans.(e)

Sol. India has been ranked 86th among 180 countries in Corruption Perception Index (CPI) 2020, released by Transparency International (Headquarter - Berlin, Germany) on 28 January 2021.

TEST SERIES
BILINGUAL

RBI
OFFICE ATTENDANT
Vacancies- 841

40 TOTAL TESTS

S18. Ans.(c)

Sol. The appointments committee (ACC) of the Cabinet has approved the appointment of Swaminathan Janakiraman and Ashwini Kumar Tewari as new Managing Directors (MDs) of State Bank of India (SBI) for a period of three years. Dinesh Kumar Khara is the current Chairman of the bank. The other two MDs of the bank are C.S. Setty and Ashwani Bhatia.

S19. Ans.(d)

Sol. Lieutenant General Chandi Prasad Mohanty has been appointed as the new Vice-chief of Army staff. He would assume the office on February 1, 2021 from Lt General SK Saini, who is superannuating on 31 January 2021.

S20. Ans.(d)

Sol. India has been ranked at 86th position among 98 countries in the new Coronavirus Performance Index released by Australia-based Lowy Institute.

S21. Ans.(c)

Sol. Prime Minister Shri Narendra Modi chaired the 35th PRAGATI meeting on 27 January 2021 to review multiple projects, grievances and programmes. PRAGATI stands for Pro-Active Governance and Timely Implementation. In the meeting ten agenda items were taken for review worth Rs. 54,675 crore, related to 15 states.

S22. Ans.(a)

Sol. New Zealand and Denmark have jointly secured first position with scores of 88. Somalia and South Sudan rank lowest at 179th position with scores of 12.

S23. Ans.(b)

Sol. New Zealand, Vietnam and Taiwan are the top three countries respectively in the index.

S24. Ans.(e)

Sol. Bharti Axa General Insurance, a joint venture between Bharti Enterprises, one of India's leading business groups, and Axa, one of the world's largest insurance companies, launched a new app "Krishi Sakha" to cater to the needs of farmers and guide them in adopting best farming practices and enhancing productivity.

S25. Ans.(c)

Sol. Italian Prime Minister, Giuseppe Conte resigned after losing his Senate majority, plunging the country into political uncertainty just as it's battling the pandemic and a recession.

S26. Ans.(a)

Sol. The vaccine alliance GAVI is an international organisation based in Geneva, Switzerland.

S27. Ans.(c)

Sol. The Union Cabinet chaired by Prime Minister Narendra Modi has approved the proposal to export indigenously-developed Akash Missile System. Akash is a short range Surface to Air Missile to protect vulnerable areas and vulnerable points from air attacks.

S28. Ans.(e)

Sol. Recently, the Indian Railways successfully completed the 180 km per hour speed trial of its new design Vistadome tourist coaches. The luxurious tourists coaches have been manufactured by the Integral Coach Factory in Chennai.

S29. Ans.(b)

Sol. The Union Minister of Earth Sciences, Dr. Harsh Vardhan inaugurated the meteorological centre (MC) of the India Meteorological Department at Leh in Ladakh via video conferencing on 29 December 2020.

S30. Ans.(b)

Sol. Akash is a short range Surface to Air Missile with a range of 25 Kms to protect vulnerable areas and vulnerable points from air attacks.

S31. Ans.(e)

Sol. Union Minister of Education Ramesh Pokhriyal 'Nishank' virtually laid the foundation stone of 'TiHAN-IIT Hyderabad', India's first Testbed for Autonomous Navigation Systems (Terrestrial and Aerial) at IIT Hyderabad.

S32. Ans.(d)

Sol. India's first pollinator park opens in Uttarakhand, will support over 40 key species. The pollinators park, which took nearly a year to build, was inaugurated by noted lepidopterist Peter Smetacek, from Butterfly Research Centre Bhimtal. Smetacek helped the forest department in setting up the park.

S33. Ans.(b)

Sol. Recently the 96th Tansen Music Festival began in Gwalior, Madhya Pradesh and will conclude at Behat village (birthplace of Tansen).

S34. Ans.(a)

Sol. The GAVI Alliance (formerly the Global Alliance for Vaccines and Immunisation) is a global health partnership of public and private sector organizations dedicated to "immunisation for all". It was founded in 2000 and is headquartered in Geneva, Switzerland.

S35. Ans.(e)

Sol. Indian Railways successfully completed the 180 km per hour speed trial of its new design Vistadome tourist coaches.

S36. Ans.(d)

Sol. The chairman & CEO of Railway Board, Vinod Kumar Yadav has been conferred with the prestigious "Eminent Engineer Award for the Year 2020".

S37. Ans.(b)

Sol. In the inaugural ceremony renowned santoor player, Pandit Satish Vyas was conferred upon the prestigious Tansen Samman.

S38. Ans.(e)

Sol. Veteran broadcaster, Indira Joseph Venniyoor passed away. She was a renowned broadcaster, All India Radio veteran & first English news announcer of Travancore Radio when its English service began in 1949.

S39. Ans.(b)

Sol. The theme for this year's awards was, 'Celebrating Compassion In Times Of Covid '.

S40. Ans.(d)

Sol. Union Minister for Road Transport and Highways, Nitin Gadkari has announced that a multi-modal logistics park in Assam.

S41. Ans.(c)

Sol. The Central government has further extended the deadline to file income tax return (ITR) for FY 2019-20 by 10 days, up to January 10, 2021. Earlier this deadline was December 31, 2020.

S42. Ans.(b)

Sol. The Central Government has approved the extension of the term of ISRO Chairman K Sivan, for a period of one year. He was due to retire on January 14, 2021. Sivan will now continue as ISRO chairman and Secretary, Department of Space up to January 14, 2022.

S43. Ans.(c)

Sol. Pimpri Chinchwad Municipal Corporation, Pune has recently signed an MoU with UNDP India to co-create India's first Social Impact Bond (SIB).

S44. Ans.(a)

Sol. The International Financial Services Centres Authority (IFSCA) has become an Associate Member of the International Organization of Securities Commissions (IOSCO). The Headquarter of IOSCO is at Madrid, Spain.

S45. Ans.(e)

Sol. ADB & India sign \$10 million loan to support project preparation to expand horticulture in Himachal Pradesh

S46. Ans.(b)

Sol. Soma Mondal has taken over as the new Chairman of Steel Authority of India Limited (SAIL) with effect from January 01, 2021. She is the first-ever women-head of the body.

S47. Ans.(d)

Sol. Prime Minister Shri Narendra Modi laid the foundation stone of Light House projects (LHPs) at six sites across six States through video conference on 1st January 2021. The LHPs will be implemented at Indore (Madhya Pradesh), Rajkot (Gujarat), Chennai (Tamil Nadu), Ranchi (Jharkhand), Agartala (Tripura) and Lucknow (Uttar Pradesh).

S48. Ans.(c)

Sol. The Defence Research and Development Organisation (DRDO) observed the 63rd Foundation Day of its establishment on January 01, 2021.

S49. Ans.(b)

Sol. Suneet Sharma, a Special Class Railway Apprentice Officer of the 1978-batch, has been appointed as the new Chairman & Chief Executive Officer (CEO) of Railway Board, Ministry of Railways and ex-officio Principal Secretary to Government of India.

S50. Ans.(a)

Sol. The Asian Development Bank (ADB) has signed a \$231 million loan with the Government of India to augment electricity generation capacity in the state of Assam.



BILINGUAL

RBI ATTENDANT
Live Mock Test
Discussion Batch

Starts Mar 22, 2021 10 AM to 2 PM

Quantitative Aptitude

S1. Ans.(d)

Sol. let numbers be a, b, c, d

ATQ, $b = 3a$; $c = 6b$

$a : b : c = 1 : 3 : 18$ or $x : 3x : 18x$

$$\frac{a+b+c}{3} = 66$$

$$x = 9$$

$$d = 4 + 66 = 70$$

$$\text{Required average} = \frac{a+d}{2} = \frac{9+70}{2} = 39.5$$

S2. Ans.(d)

Sol. let numbers be a and b respectively

ATQ, 12.5% of a = 62.5% of b

$$\frac{a}{b} = \frac{5}{1} \text{ or } a = 5x, b = x$$

$$a^2 + b^2 = 416$$

$$25x^2 + x^2 = 416$$

$$x^2 = 16$$

$x = 4$ (neglecting negative value since numbers are positive)

Smallest number = $x = 4$

Sum of numbers = $5x + x = 6x = 24$

$$\text{Required \%} = \frac{4}{24} \times 100 = 16\frac{2}{3}\%$$

S3. Ans.(b)

Sol. amount actually donated = $7000 \times \frac{90}{100} = \text{Rs. } 6300$

Let amount donated in each NGO be Rs. 2x, Rs. 3x, Rs. 4x, Rs. 5x respectively.

$$\text{Least amount donated} = \frac{6300}{14x} \times 2x = \text{Rs. } 900$$

S4. Ans.(a)

Sol. average score of Rohit = $\frac{84+79}{2} = 81.5$

Let score by Karan in Science be x.

$$\text{ATQ, } \frac{x+85}{2} = 6 + 81.5 = 87.5$$

$$x = 175 - 85 = 90$$

S5. Ans.(d)

Sol. let Anurag got x marks

$$\text{Marks obtained by Mahesh} = \frac{130}{100} \times x = 1.3x$$

$$\text{Marks obtained by Sanjay} = \frac{80}{100} \times 1.3x = 1.04x$$

$$\text{Marks obtained by Karan} = \frac{125}{100} \times 1.04x = 1.3x$$

$$\text{Required \%} = \frac{1.3x-x}{x} \times 100 = 30\%$$

S6. Ans.(b)

Sol. let total students would be 10x

$$\text{Passed students} = \frac{10x}{10} \times 9 = 9x$$

$$\text{Failed students} = 10x - 9x = x$$

$$\text{ATQ, } \frac{9x-6}{x+6} = \frac{21}{4}$$

$$36x - 24 = 21x + 126$$

$$15x = 150 \Rightarrow x = 10$$

$$\text{Total students} = 10x = 10 \times 10 = 100$$

S7. Ans.(a)

Sol. let smallest even & odd number be a & b respectively.

$$\text{ATQ, } \frac{a+a+2+a+4+a+6}{4} = \frac{b+b+2+b+4}{3} + 10$$

$$\frac{4a+12}{4} = \frac{3b+6}{3} + 10$$

$$a = b + 9$$

$$\text{Also, } a + 6 = 2(b) \Rightarrow a = 2b - 6$$

$$2b - 6 = b + 9 \Rightarrow b = 15$$

$$a = 24$$

Numbers are 24, 26, 28, 30 (even); 15, 17, 19 (odd)

$$\text{Required average} = \frac{[(24+26+28+30)+(15+17+19)]}{7}$$

$$= \frac{159}{7} = 22\frac{5}{7}$$

S8. Ans.(d)

Sol. ATQ, $\frac{50}{100}y - \frac{10}{100}x = 170$

$$\frac{40}{100}x = \frac{30}{100}y \Rightarrow \frac{x}{y} = \frac{3}{4}$$

$$\frac{50}{100} \times \frac{4}{3}x - \frac{10}{100}x = 170$$

$$x = 300 \Rightarrow y = 400$$

$$\text{Required answer} = x + y = 300 + 400 = 700$$

S9. Ans.(c)

Sol. let Pandey's salary & savings be Rs. 16x & Rs. 3x respectively.

$$\text{Expenditure} = 16x - 3x = \text{Rs. } 13x$$

$$\text{New savings} = 3x + \frac{1}{3} \times 3x = \text{Rs. } 4x$$

$$\text{New expenditure} = 13x + \frac{1}{2} \times 13x = \text{Rs. } 19.5x$$

$$\text{New salary} = 19.5x + 4x = \text{Rs. } 23.5x$$

$$\text{Required ratio} = 23.5x : 16x = 47 : 32$$

S10. Ans.(c)

Sol. let the smallest odd number be 'a' so next odd number be 'a+2' and so on

$$8^{\text{th}} \text{ number} = a + (8 - 1) \times 2 = a + 14 \text{ (using AP, nth}$$

$$\text{term} = a + (n-1)d)$$

$$\text{ATQ, } \frac{a+a+2+\dots+a+14}{8} = 10$$

$$8a + 56 = 80 \text{ (using sum of AP)}$$

$$a = \frac{80-56}{8} = 3$$

Since 'a' is smallest number, so smallest 4 numbers will be = 3, 5, 7, 9

$$\text{Required average} = \frac{3+5+7+9}{4} = 6$$

S11. Ans.(d)

Sol. let maximum marks be x

$$\frac{56}{100}x - 10 = \frac{48}{100}x + 6 \Rightarrow x = 200$$

$$\text{Marks of Sanjay} = \frac{56}{100}x = 112$$

$$\text{Passing marks} = 112 - 10 = 102$$

$$\text{Pass \%} = \frac{102}{200} \times 100 = 51\%$$

S12. Ans.(a)

Sol. required average = $\frac{7.5 \times 6 + 8.5 \times 2 + 42}{10} = 10.40$ run/over

S13. Ans.(b)

Sol. let marks scored by Ravi = x

Marks of Ronit = $\frac{90}{100}x = 0.9x$

Marks of Raj = $\frac{130}{100} \times 0.9x = 1.17x$

Marks of Jai = $\frac{120}{100} \times 1.17x = 1.404x$

Required % = $\frac{1.404x}{x} \times 100 = 140.4\%$

S14. Ans.(e)

Sol. Mohit invested 28% salary in share markets

28% of 25000 = $28 \times 250 = 7000$ rs

Remaining amount invested in rent, grocery and entertainment in the ratio 2:4:3 respectively

ATQ,

9 units = $(100 - 28)\% = 72\%$

So, 3 units = $\frac{72}{9} \times 3 = 24\%$

Required difference = $(28 - 24)\%$

= $4\% = 4 \times 250$

= 1000 rs

S15. Ans.(b)

Sol. required average = $\frac{2000 \times 2 + 1500 \times 2 + 800 + 900}{2} = \text{Rs. } 4350$

S16. Ans.(d)

Sol. Let present age of suman's son be x yr

Hence, age of suman = $(x + 25)$ yr

According to the question, $\frac{x+7}{(x+25)+7} = \frac{1}{2}$

$2x + 14 = x + 32$

$x = 32 - 14 = 18$ yrs

S17. Ans.(c)

Sol. Let present ages of Karan and Arjun be 4x & 3x years respectively

$4x = 3x + 5$

$x = 5$

Present age of Karan = $4x = 20$ years

Present age of Arjun = $3x = 15$ years

Present age of Mahesh = $\frac{20}{2} \times 5 = 50$ years

Required ratio = $(50 - 10) : (20 - 10) : (15 - 10)$

= $40 : 10 : 5 = 8 : 2 : 1$

S18. Ans.(c)

Sol. Let son's present age = x years

Then, person's present age = $(x + 16)$ year

After 2 yrs, $(x + 16) + 2 = 2(x + 2)$

$x + 18 = 2x + 4$

$x = 14$ years

Hence, son's age after 8 years = $14 + 8 = 22$ yrs

S19. Ans.(d)

Sol. Let present age of Suresh's son be x yrs

Present age of Suresh = 6x

$\frac{6x+13}{x+13} = \frac{11}{4}$

$24x + 52 = 11x + 143$

$13x = 91$

$x = 7$

Present age of suresh = $6x = 42$ yrs

S20. Ans.(b)

Sol. Let father present age be 3x

So, the son's present age will be x yrs

$\frac{3x+4}{x+4} = \frac{5}{2}$

$6x + 8 = 5x + 20$

$x = 12$

Father's age 3 yrs ago = $3x - 3$

= $36 - 3$

= 33 yrs

S21. Ans.(c)

Sol. Let present age of shivam and ayush be 'p' yrs and 'q' yrs respectively

$(p+5) = \frac{120}{100} \times p$

$(p+5) = \frac{6p}{5}$

$p = 25$

Also, $(q-6) = \left(\frac{75}{100}\right) \times q$

$q - 6 = \frac{3q}{4}$

$q = 24$

Sum of ages of shivam and ayush, 8 yrs hence = $25 + 8 + 24 + 8$

= 65 yrs

S22. Ans.(b)

Sol. Let present age of Father and his son be 3x and x yrs respectively

$\frac{3x+6}{x+6} = \frac{7}{3}$

$9x + 18 = 7x + 42$

$2x = 24$

$x = 12$

Age of son 3 yrs ago = $x - 3 = 12 - 3 = 9$ yrs

S23. Ans.(d)

Sol. After 6 yrs, let their ages be 5x, 4x, 3x and 6x yrs respectively

Then, sum of their ages at present

$(5x + 4x + 3x + 6x) - 6 \times 4 = 48$

$18x = 72$

$x = 4$

S's present age = $6x - 6 = 18$ yrs

S24. Ans.(d)

Sol. Let the initial MP at which shopkeeper received the discount be Rs 100x

$$\text{New MP} = 100x \times \frac{160}{100} = \text{Rs } 160x$$

SP (on which article is sold by Shopkeeper)

$$= 160x \times \frac{7}{10} \times \frac{3}{4} = \text{Rs } 84x$$

$$\text{CP for the shopkeeper} = \frac{84x \times 20}{21} = \text{Rs } 80x$$

$$\therefore \text{Required discount} = \frac{(100x - 80x)}{100x} \times 100 = 20\%$$

S25. Ans.(e)

Sol. Let present age of Bhagat & Abhi be 9x and 8x respectively

After 10 years.

$$\frac{9x+10}{8x+10} = \frac{10}{9}$$

$$81x + 90 = 80x + 100$$

$$x = 10$$

\therefore required difference = 10 years.

S26. Ans.(a)

Sol. If x litres of water is added to the mixture, the ratio of milk and water will be 14:5

$$\frac{14}{5} = \frac{\frac{7}{8} \times 64}{\frac{1}{8} \times 64 + x}$$

$$\frac{14}{5} = \frac{56}{x+8}$$

$$14x + 112 = 280$$

$$14x = 168$$

$$x = 12 \text{ litres}$$

S27. Ans.(e)

Sol. in mixture I juice : water = $\frac{120}{100} \times 100 : 100 = 6 : 5$

Mixtures are mixed in ratio 3 : 4

In final mixture,

$$\frac{\text{juice}}{\text{water}} = \frac{6 \times 3 + 5 \times 4}{5 \times 3 + 6 \times 4} = 38 : 39$$

S28. Ans.(b)

The container is full of 75 litre milk

$$\text{Required quantity of milk} = 75 \left(1 - \frac{15}{75}\right)^3$$

$$= 75 \left(1 - \frac{1}{5}\right)^3$$

$$= 38.4 \text{ litres}$$

S29. Ans.(e)

Sol. let initial quantity of juice be 3x litres & water be 4x litres.

$$\text{ATQ, } \frac{3x}{4x+40} = \frac{1}{4}$$

$$12x = 4x + 40$$

$$x = 5$$

$$\text{Initial quantity of mixture} = 3x + 4x = 35 \text{ litres}$$

S30. Ans.(b)

Sol. Let initial quantity of milk and water be 4x lit & 5x lit respectively.

A.T.Q,

$$\frac{4x}{5x+25} = \frac{2}{5}$$

$$20x = 10x + 50$$

$$X = 5$$

$$\text{Initial quantity of mixture} = 9x = 45 \text{ lit.}$$

S31. Ans.(d)

Sol. Let ratio of P's investment and Q's investment be x:y

Therefore, profit will be shared in the ratio 4x:5y

$$\text{Given, } \frac{4x}{4x+5y} \times 75000 = 15000$$

$$\frac{4x}{4x+5y} = \frac{1}{5}$$

$$20x = 4x + 5y$$

$$16x = 5y$$

$$y : x = 16 : 5$$

S32. Ans.(c)

Sol.

$$\begin{array}{ccc} & \text{A} & \text{B} \\ & 25000 & : & 75000 \end{array}$$

$$\therefore \text{Ratio of investment} = 1 : 3$$

$$\text{Ratio of time} = 7 : 4$$

$$\text{So, ratio of profit} = (1 \times 7) : (3 \times 4) = 7 : 12$$

$$\text{Total profit} = \frac{19}{5} \times 500 = \text{Rs. } 1900$$

S33. Ans.(c)

Sol. Amit : Deepak

Initial investment 3 : 1

$$3 \times 8 : 1 \times 12$$

$$24 : 12$$

$$2 : 1$$

Now, 1 unit = Rs 8000

$$\text{So, } (2+1) \text{ units} = 3 \text{ units} = 3 \times 8000 = \text{Rs } 24000$$

TEST SERIES

BILINGUAL



RBI

OFFICE ATTENDANT

Vacancies- 841

40 TOTAL TESTS

S34. Ans.(b)**Sol.** Ratio in which profit is distributed betweenAakash and Vikash $= (x + 2000) : (x + 3000)$

$$\frac{x+2000}{x+3000} = \frac{28000-16000}{16000}$$

$$\Rightarrow \frac{x+2000}{x+3000} = \frac{3}{4}$$

$$4x + 8000 = 3x + 9000$$

$$\Rightarrow x = \text{Rs. } 1000$$

S35. Ans.(d)**Sol.** A : B : C

Amount 2500 4500 2400

Time period 12 12 7

Reqd. ratio 25 : 45 : 14

Required difference in profit share of B and C $= (45-14) \times \frac{16800}{84}$

$$= \text{Rs } 6200$$

S36. Ans.(e)**Sol.** let actual SP be Rs. xNew selling price = Rs. $\frac{4x}{5}$

Let CP be Rs. y

$$\text{ATQ, } \frac{\frac{4x}{5} - y}{y} = \frac{20}{100} = \frac{1}{5}$$

$$\frac{4x}{5} - y = \frac{y}{5}$$

$$\frac{y}{x} = \frac{2}{3}$$

When article sold at actual selling price,

$$\text{Profit \%} = \frac{x-y}{y} \times 100 = \frac{\frac{3y}{2} - y}{y} \times 100 = 50\%$$

S37. Ans.(c)**Sol.** let CP be Rs. x

$$\text{MP} = \frac{150}{100} \times x = \text{Rs. } 1.5x$$

$$\text{SP} = \frac{80}{100} \times 1.5x = \text{Rs. } 1.2x$$

$$\text{Amount returned to Karan} = \frac{90}{100} \times 1.2x = \text{Rs. } 1.08x$$

$$\text{Profit \% (shopkeeper)} = \frac{1.2x - 1.08x}{x} \times 100 = 12\%$$

S38. Ans.(e)**Sol.** let CP be Rs. x

$$\text{MP} = \frac{130}{100} \times x = \text{Rs. } 1.3x$$

$$\text{SP (given)} = \frac{90}{100} \times 1.3x = \text{Rs. } 1.17x$$

$$\text{Earlier SP (announced)} = \frac{85}{100} \times 1.3x = \text{Rs. } 1.105x$$

$$\text{Gain} = 1.17x - 1.105x = \text{Rs. } 0.065x$$

$$0.065x = 13$$

$$x = \text{Rs. } 200$$

S39. Ans.(a)**Sol.** let CP of bags be Rs. 4x & Rs. 5x respectively.

$$\text{Total SP of bags} = \frac{110}{100} \times 4x + \frac{120}{100} \times 5x = 4.4x + 6x$$

$$= \text{Rs. } 10.4x$$

$$\text{Required Profit \%} = \frac{10.4x - 9x}{9x} \times 100 = 15\frac{5}{9}\%$$

S40. Ans.(b)**Sol.** Let cost price of the item be 100x

$$\text{Marked price of the item} = 100x + 100x \times \frac{60}{100}$$

$$= 160x$$

Selling price of items after giving discounts

$$= 160x \times \frac{90}{100} \times \frac{85}{100} = 122.4x$$

$$\text{Profit percentage} = \frac{122.4x - 100x}{100x} \times 100$$

$$= 22.4\%$$

S41. Ans.(d)**Sol.** let CP be Rs. x

$$\text{SP (Johny)} = \frac{110}{100} \times x = \text{Rs. } 1.1x$$

Since Jini calculate profit at SP

$$\frac{\text{SP} - x}{\text{SP}} \times 100 = 10$$

$$10 \text{ SP} - 10x = \text{SP}$$

$$\text{SP} = \text{Rs. } \frac{10}{9}x$$

$$\text{Required ratio} = 1.1x : \frac{10x}{9} = 99 : 100$$

S42. Ans.(c)**Sol.** Let original cost price of the article be Rs. 100x.

$$\text{So, original selling price of the article} = 100x \times \frac{110}{100}$$

$$= \text{Rs. } 110x$$

$$\text{Now, new cost price of the article} = 100x \times \frac{95}{100}$$

$$= \text{Rs. } 95x$$

$$\text{And, new selling price of the article} = \text{Rs. } (110x + 120)$$

ATQ,

$$95x \times \frac{120}{100} = 110x + 120$$

$$\Rightarrow 4x = 120$$

$$x = 30$$

$$\text{So, cost price of the article} = 100x = \text{Rs. } 3000$$

S43. Ans.(d)**Sol.** let cost price of purse be Rs 100x

$$\text{MP} = \frac{130}{100} \times 100x = \text{Rs. } 130x$$

$$\text{SP} = \frac{80}{100} \times 130x = \text{Rs. } 104x$$

$$\text{CP (3 purses)} = 3 \times 100x = \text{Rs. } 300x$$

$$\text{SP (3 purses)} = 3 \times 104x = \text{Rs. } 312x$$

But shopkeeper offered 10% extra discount

$$\text{Actual SP (3 purses)} = \frac{90}{100} \times 312x = \text{Rs. } 280.8x$$

$$\text{Loss \%} = \frac{300x - 280.8x}{300x} \times 100 = 6.4\%$$

S44. Ans.(b)**Sol.** Let the marked price of the article be a

$$\text{Then, SP} = \frac{3a}{5} = 0.6a$$

$$\text{Loss} = 10\%$$

$$\text{CP} = 0.6a \times \frac{100}{90} = \frac{2a}{3}$$

$$\text{SP at 10\% profit} = 110\% \text{ of } \frac{2a}{3} = \frac{11a}{15}$$

$$\text{So, required fraction} = \frac{11}{15}$$

S45. Ans.(d)**Sol.** let cost price of bag be Rs 100x

$$MP = \frac{120}{100} \times 100x = \text{Rs. } 120x$$

$$SP \text{ (only first discount)} = \frac{90}{100} \times 120x = \text{Rs. } 108x$$

$$SP \text{ (both discount provided)} = 108x \frac{100-d}{100} =$$

$$\text{Rs } (108x - 1.08xd)$$

$$ATQ, 108x - (108x - 1.08xd) = 27$$

$$1.08xd = 27 \dots\dots\dots (i)$$

$$\text{Also, } (108x - 1.08xd) - 100x = 13$$

$$8x - 27 = 13$$

$$x = 5$$

$$CP = 100x = \text{Rs } 500$$

S46. Ans.(c)**Sol.** Let total work be 30 units (LCM of 15, 30, 10)

$$\text{Efficiency Arshad} = \frac{30}{15} = 2 \frac{\text{units}}{\text{day}}$$

$$\text{Sanjay} = \frac{30}{30} = 1 \frac{\text{units}}{\text{day}}$$

$$\text{Arshad, Sanjay, Vidya} = \frac{30}{5} = 6 \frac{\text{units}}{\text{day}}$$

$$\text{Vidya} = 6 - (2 + 1) = 3 \frac{\text{units}}{\text{day}}$$

Since work is completed in 5 days, work done by Vidya = $5 \times 3 = 15$ units

$$\text{Amount paid to Vidya} = \frac{600}{30} \times 15 = \text{Rs. } 300$$

S47. Ans.(b)**Sol.** 1 day wage of a man & a woman = $\frac{1000}{8} = \text{Rs. } 125$

$$\text{Efficiency ratio man : woman} = 4 : 1$$

$$\text{Daily wage of a woman} = \frac{125}{5} \times 1 = \text{Rs. } 25$$

S48. Ans.(c)**Sol.**

$$\frac{1}{P} + \frac{1}{Q} = \frac{1}{15} \dots\dots (1)$$

$$\frac{1}{P} + \frac{1}{Q} + \frac{1}{R} = \frac{1}{9} \dots\dots (2)$$

By subtracting eqn (1) from (2), we get

$$\frac{1}{R} = \frac{1}{9} - \frac{1}{15}$$

$$\frac{1}{R} = \frac{5-3}{45}$$

$$R = 22.5 \text{ days}$$

S49. Ans.(c)**Sol.** Let leak empty it in x hr, then

$$\frac{1}{15} - \frac{1}{x} = \frac{1}{18}$$

$$\frac{1}{x} = \frac{1}{15} - \frac{1}{18}$$

$$x = 90 \text{ hrs}$$

S50. Ans.(b)**Sol.**

	Time (days)	Work (units)	Efficiency (units/day)
A + B	12	300	25
A	25		12
B			25 - 12 = 13

Half work done by A & half by B

$$\text{Required time} = \frac{150}{12} + \frac{150}{13} = \frac{625}{26} = 24 \frac{1}{26} \text{ days}$$

S51. Ans.(c)**Sol.** Here, Pipe A alone and Pipe B alone can fill the tank in 20 min and 30 min respectively and Pipe C alone can empty the tank in 10 min

Then, total work = 60 units

Therefore, efficiency of pipe A and pipe B are 3 units/min and 2 units/min respectively and efficiency of pipe C is 6 units/min

Total efficiency when all 3 pipes are opened simultaneously = $3 + 2 - 6 = -1$ unit/minTotal time taken to empty the tank if the tank is completely full = $\frac{60}{1}$

= 60 min (as total efficiency of all 3 pipes is -1)

S52. Ans.(d)**Sol.** 1 day work of C (alone) = $\frac{1}{6} - \left(\frac{1}{15} + \frac{1}{12}\right) = \frac{1}{60}$ units

Time taken by C alone to complete the work = 60 days

S53. Ans.(b)**Sol.** A.T.Q,

Tank filled by all 3 pipes together in 1 hour

$$= \frac{1}{5} + \frac{1}{10} - \frac{1}{15} = \frac{7}{30} \text{ units.}$$

Time taken by all 3 pipes together to fill the tank

$$= \frac{30}{7} \text{ hours.}$$

BILINGUAL

RBI ATTENDANT
Live Mock Test
Discussion Batch

Starts Mar 22, 2021 **10 AM to 2 PM**

S54. Ans.(a)**Sol.** P : Q

Efficiency 3 : 2

Total work $= (3+2) \times 24$ $= 120$ units

So, Q alone can complete the same work in

$$= \frac{120}{2} = 60 \text{ days}$$

S55. Ans.(c)**Sol.** In 2 hrs, pipe can fill $\frac{1}{2}$ part of the tankIn 2 hrs, the pipe and the leakage can fill $\frac{1}{3}$ part of the tankSo, in 2 hr, the leakage can empty $(\frac{1}{2} - \frac{1}{3})$ or $\frac{1}{6}$ th part of the tankIn 2 hrs, the leakage will empty $(\frac{55}{2})$ litre

$$(\frac{1}{6}) \text{ of tank} = (\frac{55}{2}) \text{ litre}$$

$$\text{Capacity of the tank} = (\frac{55}{2}) \times 6$$

 $= 165$ litre**S56. Ans.(b)****Sol.** time taken by train A to cover distance = 1 hr

Time taken by train B to cover distance = 40 minutes

$$\text{Speed of train A} = \frac{24}{1} = 24 \text{ kmph}$$

$$\text{Speed of train B} = 36 \text{ kmph}$$

Distance covered by train A in (1 hr - 40 min) 20

$$\text{minutes} = 24 \times \frac{20}{60} = 8 \text{ km}$$

$$\text{Time taken to cross each other} = \frac{24-8}{24+36} = \frac{16}{60} \text{ hr} = 16 \text{ min}$$

$$\text{Time of crossing} = 6:20 + 0:16 = 6:36 \text{ AM}$$

S57. Ans.(a)**Sol.** let speed of passenger train be S kmph.Distance travelled by superfast train in 5 hr = 90×5

$$= 450 \text{ km}$$

Therefore, passenger train takes 15 hr to cover the distance of 450 km

$$\text{Speed of passenger train} = \frac{450}{15} = 30 \text{ km/hr}$$

S58. Ans.(e)**Sol.** distance covered by Sanjay in 20 min

$$= 5 \times \frac{20}{60} = \frac{5}{3} \text{ km}$$

$$\text{Time taken to catch Sanjay by Anurag} = \frac{\frac{5}{3}}{12-5} = \frac{5}{21} \text{ hours}$$

Distance covered by Anurag to catch Sanjay

$$= 12 \times \frac{5}{21} = \frac{20}{7} \text{ km} \approx 3 \text{ kms}$$

S59. Ans.(b)**Sol.** Let speed of Ravi and Maanik be $3x$ km/hr and $4x$ km/hr respectivelyRelative speed $= 3x+4x=7x$ km/hr

$$7x \times \frac{3}{60} = 4.2$$

$$x = 12 \text{ km/hr}$$

Difference in their speed $= 4x - 3x = x = 12$ km/hr**S60. Ans.(a)****Sol.** Let speed of train be x m/s and its length be L metresAccording to 1st condition

$$L = 15x \dots\dots\dots (1)$$

According to 2nd condition

$$L+500 = 45x \dots\dots\dots (2)$$

From (1) and (2), we will get

$$500 = 30x$$

$$15x = 250 \text{ m}$$

Therefore, length of train is 250 metres

S61. Ans.(c)**Sol.** let speed of stream be x km/hrSpeed of boat in still water $= 4x$ km/hr

$$\frac{220}{4x+x} + \frac{108}{4x-x} = 20$$

$$\frac{220}{5x} + \frac{108}{3x} = 20$$

$$\frac{44}{x} + \frac{36}{x} = 20$$

$$\frac{80}{x} = 20$$

$$x = 4 \text{ km/hr}$$

speed of stream $= 4$ km/hrspeed of boat in still water $= 4x = 16$ km/hr

$$\text{Reqd. sum} = \frac{40}{20} + \frac{48}{12} = 2 + 4 = 6 \text{ hrs}$$

S62. Ans.(e)

$$\text{Sol. actual journey time} = \frac{20}{5} = 4 \text{ hours}$$

$$\text{New journey time} = \frac{40}{100} \times 4 = 1.6 \text{ hour}$$

$$\text{New speed} = \frac{20}{1.6} = 12.5 \text{ kmph}$$

$$\text{Required \%} = \frac{12.5-5}{5} \times 100 = 150\%$$

S63. Ans.(a)**Sol.** Relative speed $= 90 - 60 = 30$ km/hr

Distance travelled by Shatabdi exp. In 2 hrs

$$= 60 \times 2 = 120 \text{ km}$$

Time required to cover 120 km by duronto exp.

$$= \frac{120}{30} = 4 \text{ hr}$$

Distance travelled by duronto exp. In 4 hrs

$$= 90 \times 4 = 360 \text{ km}$$

S64. Ans.(e)**Sol.** Let speed of stream be u km/hr

According to the question,

$$\frac{54}{15+u} + \frac{54}{15-u} = 7.5$$

$$\frac{18}{15+u} + \frac{18}{15-u} = \frac{5}{2}$$

$$\frac{18(15-u+15+u)}{(15+u)(15-u)} = \frac{5}{2}$$

$$216 = 225 - u^2$$

$$u^2 = 9$$

$$u = 3 \text{ km/hr}$$

Time required to travel 48 km in upstream

$$= \frac{48}{15-3} = \frac{48}{12} = 4 \text{ hrs}$$

S65. Ans.(a)**Sol.** total distance = $4 \times \frac{30}{60} + 10 \times \frac{20}{60} + 50 \times \frac{10}{60} = \frac{41}{3}$ kmsTotal time taken = $30 + 20 + 10 = 60$ minutes = 1 hour

$$\text{Average speed} = \frac{\frac{41}{3}}{1} = \frac{41}{3} \text{ kmph} = 13.67 \text{ kmph}$$

S66. Ans.(b)**Sol.** Distance covered by Ashish while walking = $\frac{72}{2}$

$$= 36 \text{ km}$$

Distance covered by Ashish while running = $72 - 36$

$$= 36 \text{ km}$$

$$\text{Total time required} = \frac{36}{8} + \frac{36}{12}$$

$$= 4.5 + 3$$

$$= 7.5 \text{ hrs}$$

S67. Ans.(c)**Sol.** distance covered is directly proportional to speed
When they start at same time, they will cover distance in ratio of their speedsLet distance covered by Kappu & Chandu be $5x$ km & $6x$ km respectively

$$\text{Required answer} = \frac{6x-5x}{6x+5x} \times 110 = 10 \text{ kms}$$

S68. Ans.(c)**Sol.** Let the speed of Abhishek and Rahul be $6x$ and $5x$ respectively.

$$\text{Required time} = \frac{6x \times 5}{5x} = 6 \text{ hours.}$$

S69. Ans.(a)**Sol.** let speed of Manoj & Shreya be x & y kmph respectivelyLet Manoj covers D km in t hours

$$\text{ATQ, } x = \frac{D}{t} \text{ kmph}$$

$$y = \frac{2D}{\frac{t}{2}} = \frac{4D}{t} \text{ kmph}$$

$$x : y = 1 : 4 \text{ or } a : 4a$$

Since distance travelled by both will be same (Shreya catches him)

Let time taken by Shreya to cover $20/3$ km be k hours

$$x \left(k + \frac{30}{60} \right) = yk$$

$$ak + \frac{a}{2} = 4ak$$

$$k = \frac{1}{6} \text{ hours} = 10 \text{ min}$$

$$\text{Speed of Shreya} = \frac{20}{3} \times 6 = 40 \text{ kmph}$$

S70. Ans.(b)**Sol.** Here, the total distance between P to Q is 594 kmRelative Speed = $(63+54)$ km/hr

$$= 117 \text{ km/hr}$$

Distance travelled by Train A in 2 hrs = $63 \times 2 = 126$ kmRemaining distance = $594 - 126$

$$= 468 \text{ km}$$

Time required to cover the remaining distance = $\frac{468}{117} = 4$ hrsDistance travelled by Train B in 4 hr = $54 \times 4 = 216$ km

Both train will meet at 216 km distance from Q

S71. Ans.(d)**Sol.** In still water, the speed of boat = $\frac{105}{6} = 17.5$ km/hr.And let the rate of stream be V km/hr

According to the question,

$$\frac{V}{(17.5-V)} = \frac{9}{26}$$

$$26V = 157.5 - 9V$$

$$35V = 157.5$$

$$V = 4.5 \text{ km/hr}$$

Total time taken to travel 364 km roundtrip

$$= \frac{364}{(17.5-4.5)} + \frac{364}{(17.5+4.5)}$$

$$= \frac{364}{13} + \frac{364}{22}$$

$$= 44.54 \text{ hrs}$$

$$= 45 \text{ hrs. (approx.)}$$

S72. Ans.(c)**Sol.** when time is same then speed is directly proportional to distance coveredLet speed of Dhoni, Rohit & Virat be x kmph, y kmph & z kmph respectively

$$x : y = 1 : 3 \text{ or } a : 3a$$

$$z = \frac{150}{100} \times 3 = 4.5a \text{ kmph}$$

$$\text{ATQ, } \frac{D}{a+4.5a} = 2$$

$$D = 11a \text{ km}$$

$$\text{Required time} = \frac{D}{4.5a} = \frac{11a}{4.5a} = 2.44 \text{ hours}$$

S73. Ans.(b)**Sol.** Downstream speed = $\frac{36}{4} = 9$ km/hrSpeed of the current = $\frac{1}{3} \times 9 = 3$ km/hrSpeed of the boat = $9 - 3 = 6$ km/hrNow, Upstream speed = $6 - 3 = 3$ km/hr

$$\text{Total time taken} = \frac{78}{3} = 26 \text{ hr}$$

S74. Ans.(b)

Sol. Let speed of current be x kmph

ATQ,

$$\frac{10.8}{(21-x)} = \frac{36}{60}$$

$$\Rightarrow x = 3 \text{ kmph}$$

Now, downstream speed = $21 + 3 = 24$ kmph

$$\text{Total time taken} = \frac{60}{24}$$

$$= 2 \text{ hours } 30 \text{ minutes}$$

S75. Ans.(a)

Sol. Total distance covered = $180 + 144 + 168 + 182$

$$= 674 \text{ km}$$

$$\text{Total time taken} = \frac{180}{20} + \frac{144}{18} + 14 + \frac{182}{14}$$

$$= 9 + 8 + 14 + 13 = 44 \text{ hours}$$

$$\text{Average speed} = \frac{674}{44} = 15\frac{7}{22} \text{ kmph}$$

S76. Ans.(c)

Sol. let length and breadth of rectangle be l, b cm respectively

Let radius of circle be r cm

$$2\pi r = 44$$

$$r = 7 \text{ cm}$$

$$b = 2r = 14 \text{ cm}$$

$$l = 150\% \text{ of } b = 21 \text{ cm}$$

$$\text{Area of rectangle} = 21 \times 14 = 294 \text{ cm}^2$$

S77. Ans.(b)

Sol. let side of 4 squares be a, b, c & d cm respectively

$$a = \frac{24}{4} = 6 \text{ cm}$$

$$b = \frac{32}{4} = 8 \text{ cm}$$

$$c = \frac{40}{4} = 10 \text{ cm}$$

$$d = \frac{48}{4} = 12 \text{ cm}$$

Perimeter of new square = $a + b + c + d$

$$= 6 + 8 + 10 + 12 = 36 \text{ cm}$$

$$4(\text{side}) = 36$$

$$\text{side} = 9 \text{ cm}$$

$$\text{Required area} = \text{side}^2 = 9^2 = 81 \text{ cm}^2$$

S78. Ans.(b)

Sol. let side of larger & smaller square be a & b cm respectively.

$$a - b = 3$$

$$a^2 - b^2 = 36$$

$$(a - b)(a + b) = 36$$

$$(a + b) = 12$$

$$\text{Side of larger square} = a = \frac{12+3}{2} = 7.5 \text{ cm}$$

S79. Ans.(d)

Sol. Let side of square be a and length and breadth of rectangle be l and b respectively

$$4a = 2[2(l+b)]$$

$$4a = 4(l+b)$$

$$a = l+b$$

it is given that $l \times b = 36$

But, we can't determine value of $l+b$

Hence, area of square cannot be determined.

S80. Ans.(d)

Sol. let side of squares be ' a ' & ' b ' units respectively.

$$\frac{a^2}{b^2} = \frac{289}{169}$$

$$\frac{a}{b} = \frac{17}{13}$$

$$\frac{a}{b} = \frac{17}{13}$$

$$\text{Required ratio} = \frac{\sqrt{2}a}{\sqrt{2}b} = 17 : 13$$

S81. Ans.(d)

Sol. side of square = $\sqrt{25} = 5 \text{ cm}$

Since non-parallel sides are equal,

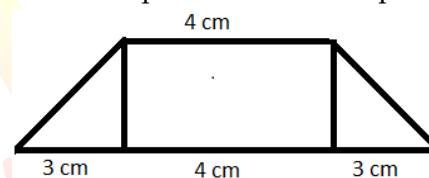

$$\text{Height of trapezium} = \sqrt{5^2 - 3^2} = 4 \text{ cm}$$

$$\text{Area of trapezium} = \frac{1}{2}(\text{base}_1 + \text{base}_2) \times \text{height}$$

$$\frac{1}{2} \times (4 + 10) \times 4 = 28 \text{ cm}^2$$

S82. Ans.(b)

Sol. Let the length(l) and breadth(b) of the rectangle be $20x$ and $10y$ respectively.

$$\text{Area of the rectangle} = l \times b = 20x \times 10y = 200xy$$

When length and breadth of the rectangle is increased by 20% and 10% respectively,

then new length and new breadth of rectangle will be $24x$ and $11y$ respectively

$$\text{new area of rectangle} = 24x \times 11y = 264xy$$

$$\% \text{ increase in area of the rectangle} = \frac{264xy - 200xy}{200xy} \times 100$$

$$= 32\%$$

S83. Ans.(e)

Sol. let side of square be x cm

$$\frac{x^2}{10x} = \frac{4}{5}$$

$$x = 8 \text{ cm}$$

$$\text{Diagonal of square} = \sqrt{2}x = 8\sqrt{2} \text{ cm}$$

S84. Ans.(b)

Sol. A.T.Q,

$$2 \times \frac{22}{7} \times r = 88$$

$$\therefore r = 14 \text{ cm}$$

So, side of square = 28 cm

$$\begin{aligned} \text{Required ratio} &= \frac{22}{7} \times 14 \times 14 : 28 \times 28 \\ &= 11 : 14 \end{aligned}$$

S85. Ans.(a)

Sol. let height between parallel sides be h cm

$$\text{ATQ, } \frac{\sqrt{3}}{4} (6)^2 = \frac{1}{2} \times (5 + 7) \times h$$

$$h = \frac{3\sqrt{3}}{2} \text{ cm}$$

S86. Ans.(a)

Sol. SI = 24000 - 20000 = Rs. 4000

$$4000 = \frac{20000 \times 2 \times R}{100}$$

$$R = 10\%$$

$$\text{Required amount} = 20000 + \frac{20000 \times 12 \times 3}{100} = \text{Rs. 27200}$$

S87. Ans.(a)

Sol. ATQ,

$$\frac{x \times 14 \times 3}{100} - \frac{x \times 10 \times 3}{100} = 120$$

$$\frac{(42-30)x}{100} = 120$$

$$x = \text{Rs. 1000}$$

$$\text{Required answer} = 5x = 5 \times 1000 = \text{Rs. 5000}$$

S88. Ans.(c)

$$\text{Sol. ATQ, } \frac{P \times 10 \times 2}{100} + 200 = \frac{P \times 20 \times x}{100}$$

$$\frac{20Px}{100} - 200 = \frac{20P}{100}$$

$$\frac{20P}{100} = \frac{20 \times 5000}{100} - 200 = 800$$

$$P = \text{Rs. 4000}$$

$$x = \frac{5000}{4000} = \frac{5}{4} \text{ years or 15 months}$$

S89. Ans.(c)

Sol. Total interest received in 8 yrs = 2408 - 1400 = Rs 1008

$$\text{Interest for 1st 4 years} = \frac{1400 \times 4 \times 12}{100} = \text{Rs 672}$$

So, interest for last 4 years = 1008 - 672 = Rs 336

$$\text{Interest rate for last 4 years} = \frac{336 \times 100}{1400 \times 4} = 6\%$$

S90. Ans.(b)

Sol. let rate of interest be R%

$$SI = 15000 - 12000 = \text{Rs. 3000}$$

$$3000 = \frac{12000 \times R \times 18}{12 \times 100}$$

$$R = \frac{100}{6} \%$$

$$\text{Required amount} = 5000 + \frac{5000 \times 100 \times 30}{100 \times 6 \times 12} = \text{Rs. 7083.33}$$

S91. Ans.(a)

Sol. Overall rate for 2 yrs at the rate of 10% compounded yearly = $10 + 10 + \frac{10 \times 10}{100} = 21\%$

According to the question,

$$21\% = 672$$

$$100\% = \frac{672}{21} \times 100 = 3200 \text{ rs}$$

$$\text{Simple interest} = \frac{3200 \times 14 \times 4}{100}$$

$$= \text{Rs 1792}$$

S92. Ans.(c)

Sol. let rate of interest be R% & principal be Rs. P

$$SI = 2P - P = \text{Rs. } P$$

$$P = \frac{P \times R \times 5}{100}$$

$$R = 20\%$$

To become 12 times, $SI = 12P - P = \text{Rs. } 11P$

$$11P = \frac{P \times 20 \times T}{100} \text{ where } T \text{ is time period in years}$$

$$T = 55 \text{ years}$$

S93. Ans.(a)

Sol. Let R be effective interest and P be principal amount

$$\text{So, } R = \frac{20}{2} = 10\%$$

And, period of time = $2 \times 2 = 4$ (as it is compounded half-yearly)

$$C.I = P \left(1 + \frac{R}{100}\right)^4 - P$$

$$= 4000 \left(1 + \frac{10}{100}\right)^4 - 4000$$

$$= \text{Rs 1856.4}$$

S94. Ans.(c)

Sol. let sum be Rs. P

When compounding half-yearly, rate = $\frac{20}{2} = 10\%$

Effective interest rate for a year when compounding half-yearly = $10 + 10 + \frac{10 \times 10}{100} = 21\%$

$$\text{ATQ, } P \left(1 + \frac{21}{100}\right) - P \left(1 + \frac{20}{100}\right)^1 = 10$$

$$\frac{P}{100} = 10$$

$$P = \text{Rs. 1000}$$

TEST SERIES
BILINGUAL



RBI
OFFICE ATTENDANT
Vacancies- 841

40 TOTAL TESTS

S95. Ans.(b)

$$\text{Sol. S.I.} = \frac{P \times R \times T}{100} \\ = \frac{10000 \times 12.5 \times 2}{100} = 2500 \text{ Rs.}$$

S96. Ans.(c)

Sol. total possible outcomes = $6^2 = 36$

Favourable events = prime number on each dice but sum should not be even

$$= (2,3) (2,5) (3,2) (5,2)$$

$$\text{Required probability} = \frac{4}{36} = \frac{1}{9}$$

S97. Ans.(e)

Sol. total possible outcomes = $6^2 = 36$

Favourable events = sum should be divisible by 6

$$= (1,3) (2,2) (2,6) (3,1) (3,5) (4,4) (5,3) (6,2) (6,6)$$

$$\text{Required probability} = \frac{9}{36} = \frac{1}{4}$$

S98. Ans.(a)

$$\text{Sol. required probability} = \frac{{}^{20}C_1 \times {}^{10}C_1}{{}^{30}C_2} = \frac{20 \times 10 \times 2}{30 \times 29} = \frac{40}{87}$$

S99. Ans.(c)

$$\text{Sol. required probability} = \frac{{}^{15}C_3 + {}^{10}C_3}{{}^{25}C_3} = \frac{455 + 120}{2300} = \frac{1}{4}$$

S100. Ans.(a)

Sol. In basket, there are 8 red balls and 6 green balls

$$\text{Probability(both being either red or blue)} = \frac{{}^8C_2 + {}^6C_2}{{}^{14}C_2} \\ = \frac{{}^8C_2 + {}^6C_2}{{}^{14}C_2} \\ = \frac{28 + 15}{91} = \frac{43}{91}$$

English Language

S1. Ans.(b)

Sol. Combination A-D successfully forms a grammatically viable and contextually meaningful sentence as the relevant phrases are of similar context and in appropriate similar context and in appropriate grammatical syntax. The coherent sentence thus formed is, "Perhaps, a century from now, future historians will look back at our Facebook posts and Twitter feeds to discover a society that rather willingly inverted the diary-writing habits of its ancestors."

S2. Ans.(b)

Sol. Combination B-E and C-F successfully form grammatically viable and contextually meaningful sentence as the relevant phrases are of similar context and in appropriate grammatical syntax.

S3. Ans.(c)

Sol. Combination A-F forms grammatically viable and contextually meaningful sentence as the relevant phrases are of similar context and in appropriate grammatical syntax. The sentence thus formed is, "There is emerging international recognition that women's participation is key to effective climate action".

S4. Ans.(c)

Sol. Combination A-F forms grammatically viable and contextually meaningful sentence as the relevant phrases are of similar context and in appropriate grammatical syntax. The sentence thus formed is, "Over time, there are changes that take place in the composition of species that constitute an ecological community."

S5. Ans.(b)

Sol. Combination A-F forms grammatically viable and contextually meaningful sentence as the relevant phrases are of similar context and in appropriate grammatical syntax. The sentence thus formed is, "The thoughts and other functions of the brain can be influenced by factors that lie beyond the realm of the body."

S6. Ans.(d)

Sol. IL&FS has appointed advisers to prepare a resolution plan, (C) and (E) makes a perfect match. The company along with its subsidiaries is facing a liquidity crisis, (A) and (F) makes a perfect match.

S7. Ans.(d)

Sol. For big companies, there are instances of even the infrastructure getting damaged, Sentence (C) and (F) makes proper combination as a sentence. The increase in MSP for rabi crops comes just ahead of the RBI monetary policy announcement, (A) and (E) makes the perfect match as in sentence.

S8. Ans.(c)

Sol. Only sentence (A) and (D) makes a perfect match as a sentence, India will be the third largest aviation market globally a year sooner.

S9. Ans.(b)

Sol. Only sentence (B) and (F) makes a perfect match as they both together states that "All the sectoral indices closed in the red, with 22 of the 30 Sensex stocks finishing lower."

S10. Ans.(c)

Sol. Only sentence (A) and (F) makes a perfect match as a sentence, "A writer needs quiet and peaceful environment around him in order to write."

S11. Ans.(d)

Sol. Wanting- lacking, sentence (C) and (E) makes a perfect match

Mercurial-unpredictable changes in mood, (A) and (F) makes a perfect match.

S12. Ans.(d)

Sol. Platitude- a trite or obvious remark, (A) and (E) makes the perfect match as in sentence (A) professor is talking about some statements and in sentence (E) those statements are considered as mere remarks only. Sentence (C) and (F) makes proper combination as the word 'gap' is used in sentence (C) and in sentence (F) this 'gap' between two things have been explained.

S13. Ans.(c)

Sol. Only sentence (A) and (D) makes a perfect match as in sentence (D) the natural calamity is stated that recently happened in Kerela and in sentence (A) the environment ministry, led by Madhav gadkil is stated.

S14. Ans.(b)

Sol. Only sentence (B) and (F) makes a perfect match as they both together states that there is a new current proposal which has a slightly expanded form of amendments passed by assembly.

S15. Ans.(c)

Sol. Only sentence (A) and (F) makes a perfect match as both are talking of a person, Leaderfield. None of the two sentences make the meaningful coherent sense.

S16. Ans.(b)

Sol. Qualm- uneasiness about the fitness of an action, sentence A and F makes grammatically and contextually a perfect match.

Staid- Characterized by dignity and propriety, sentence B and D makes grammatically and contextually a perfect match.

Hence option (b) is the correct answer choice.

S17. Ans.(c)

Sol. Abysmal- extremely bad, only sentence A and E makes grammatically and contextually a perfect match. Hence option (c) is the correct answer choice.

S18. Ans.(a)

Sol. malodorous- having and unpleasant smell, Obliging- willing to do a service or kindness, only sentence B and F makes grammatically and contextually a perfect match. Hence option (a) is the correct answer choice.

S19. Ans.(c)

Sol. Dispatched- dispose of rapidly and without delay. Convivial- describing a lively atmosphere, sentence C and F makes grammatically and contextually a perfect match.

Hence option (c) is the correct answer choice.

S20. Ans.(c)

Sol. sordid- involving ignoble actions and motives, sentence A and E makes grammatically and contextually a perfect match.

Aphorism- a short instructive saying about a general truth, sentence B and F makes grammatically and contextually a perfect match.

Inkling- a slight suggestion or vague understanding, sentence C and D makes grammatically and contextually a perfect match.

Hence option (c) is the correct answer choice.

S21. Ans.(d)

Sol. Out of all the given options, only combination of sentences (A) and (E) makes a grammatically and contextually correct sentence. Hence, option (d) is the correct answer. There can be some confusion regarding B-E because even though it is illogical but it can make some sense if we want to but the presence of B-F makes it conclusive that option (c) is the incorrect choice.

S22. Ans.(c)

Sol. Option (c) is the correct choice for the given question.

A-D and A-E make the meaningful sentences while other are grammatically and contextually incorrect.

S23. Ans.(c)

Sol. Out of all the given options, only combination of sentences (B) and (F) makes a grammatically and contextually correct sentence. Hence, option (c) is the correct answer.

BILINGUAL

RBI ATTENDANT

Live Mock Test Discussion Batch

Starts Mar 22, 2021 10 AM to 2 PM

S24. Ans.(b)

Sol. Out of all the given options, only combination of sentences (A) and (F) makes a grammatically and contextually correct sentence. Hence, option (b) is the correct answer.

S25. Ans.(b)

Sol. Out of all the given options, only combination of sentences (A) and (E) makes a grammatically and contextually correct sentence. Hence, option (b) is the correct answer.

S26. Ans.(c)

Sol. Option (c) is the correct choice as it provides an appropriate arrangement of the sentence as follows, "Conducting a peace process with Pakistan has emerged as one of India's acute strategic headaches."

S27. Ans.(e)

Sol. Option (e) is the most appropriate answer as it provides a correct arrangement of the sentence. The sentence will be as follows: "While a surprisingly large number of millennials have delayed the traditional milestones of adulthood, they are nevertheless entering their peak spending years."

S28. Ans.(e)

Sol. Option (e) is the most suitable answer choice as it arranges the sentence in a proper way. The sentence is as follows: "Prose is an eclectic collection, and you'd hardly expect to be surprised with a negative take in an introduction to a classic."

S29. Ans.(d)

Sol. Option (d) is the correct option as the sequence ACBDE provides the suitable arrangement of the sentence. The arranged sentence will be as follows: "Societies that bar their critics aren't protecting themselves for they are advertising their weakness."

S30. Ans.(c)

Sol. Option (c) is the correct choice as it provides the correct arrangement of the sentence which is as follows: "Going after personal assets of promoters who have been made to stand guarantee for the company's loans – violates the principle of limited liability."

S31. Ans.(c)

Sol. Option (c) is the correct choice as it provides a better arrangement of the sentence. The sentence will be as follows: "The rise in average global temperature by 1.5 degree Celsius is inevitable soon unless measures to cut CO2 emissions are not undertaken."

S32. Ans.(d)

Sol. Option (d) is the correct choice as it provides the most suitable arrangement for the sentence. The corrected sentence will be as follows: "Museum enthusiasts can now admire the rare collections of jewels, antiques, fossils, and biological specimens in India's oldest and biggest museum without stirring out of their homes."

S33. Ans.(b)

Sol. Option (b) is the most appropriate choice as it arranges the sentence in a most suitable way. The sentence will be as follows: "Our society only associates emotions like hatred, pity and ignorance with people with disabilities and these ideas could have been used in a less humiliating manner."

S34. Ans.(d)

Sol. Option (d) is the most apt choice. The arranged sentence will be as follows: "Bringing in competition and choice in supply for the final consumer has long been an aim of electricity reform and remains central to the amendments."

S35. Ans.(e)

Sol. Option (e) is the correct explanation for the question. The arranged statement will be "Delhi's assertion of "strategic autonomy" and desire for multipolarity will be seriously tested in the coming months."

S36. Ans.(b)

Sol. Option (b) is the most appropriate choice. The correct sequence of the statement is BCDEA. The sentence will be as follows: "Normally the cooling of the nuclear fuel is done by the heavy water of the primary heat transport system."

S37. Ans.(d)

Sol. Option (d) is the most suitable choice which provides the correct arrangement of the sentence. The correct sequence of the statement is AEBCD. The above sentence is as follows: "Size and usage of kangaroo teeth revealed that they diversified with spread of the grasslands during the mid-Pliocene epoch only."

S38. Ans.(b)

Sol. Option (b) is the most appropriate choice which gives the best arrangement for the statement. The sentence will be arranged as follows: "Some university researchers studying properties of complex biological systems using computational methods found a response to questions of why life exists, diversifies and fills the earth."

S39. Ans.(e)

Sol. Option (e) is the most apt choice which arranges the sentence in a proper way. The sentence is as follows: "The central bank changed its stance from neutral to calibrated tightening, indicating that there was no possibility of a cut in rates in the near future."

S40. Ans.(c)

Sol. Option (c) is the most suitable choice. The proper arranged sentence will be as follows: "Belonging to this community does not mean we give up who we are, our personal beliefs and tastes implying that we constantly evaluate these beliefs on the touchstone of constitutional morality."

S41. Ans.(b)

Sol. The correct sequence is CABED as it arranges the sentence in the best way as follows: "We should make school education to be free of cost for girls so that they can study easily."

S42. Ans.(a)

Sol. The correct sequence is DBAEC as it arranges the sentence properly in the way as follows: "Public Sector Banks are pulling back on credit disbursement to lower rated companies."

S43. Ans.(b)

Sol. The correct sequence of the statement is EBDAC as it arranges the sentence as follows: "Personality comes from ego while innocence comes from a childlike nature which makes you feel light."

S44. Ans.(d)

Sol. Option (d) provides the correct sequence for the arrangement of the sentence. The proper arranged sentence is as follows: "There is a likelihood of extinction of the human species as a consequence of nuclear war."

S45. Ans.(c)

Sol. The correct sequence is BADEC as the sentence can be arranged as follows: "Illustrating a life with vivid pictures detracts the reader's understanding of the prose itself."

S46. Ans.(b)

Sol. The correct sequence is EACDB as the sentence can be arranged as follows: "Matter and electricity are concentrated exclusively in certain finite units, electrons and protons."

S47. Ans.(d)

Sol. All of the options are incorrect except option (d) as it properly arranges the sentence as follows : "The perfection of our personality depends mostly on our training in truth and love ,upon ideals that go to the root of our being."

S48. Ans.(e)

Sol. Option (e) is the most appropriate choice. i.e. CABDE as it provides the best sequence to arrange the sentence in a proper way as follows : "The country through which we had been travelling for days had an original beauty with stretches of wide plains across the wide country."

S49. Ans.(b)

Sol. Option (b) is the most appropriate choice as it provides the correct sequence for the arrangement of the sentence as follows: "Competition from Yahoo and Microsoft posed a greater challenge to Google following the disclosure about its mammoth profitability."

S50. Ans.(c)

Sol. Option (c) is the most suitable choice as it provides the correct sequence for the proper arrangement of the sentence which is as follows: "We also create learning space through the kind of speech we utter and the silence from which true speech emanates ."



TEST SERIES
BILINGUAL



RBI
OFFICE ATTENDANT
Vacancies- 841
40 TOTAL TESTS

Reasoning Ability

Solutions (1-5):

Floor	Person
7	R
6	N
5	X
4	T
3	M
2	W
1	Z

S1. Ans.(e)

S2. Ans.(a)

S3. Ans.(d)

S4. Ans.(c)

S5. Ans.(a)

Solutions (6-10):

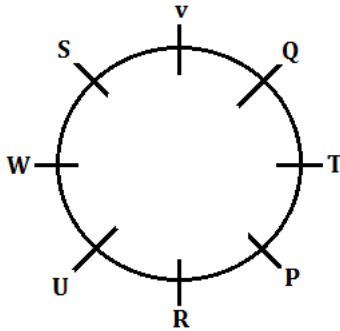

S6. Ans.(d)

S7. Ans.(b)

S8. Ans.(b)

S9. Ans.(e)

S10. Ans.(a)

Solutions (11-15):

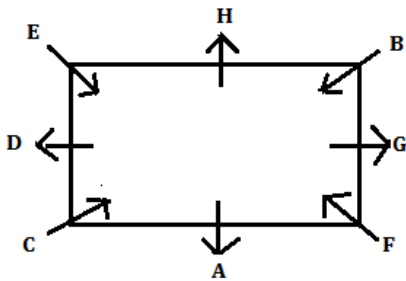

S11. Ans.(b)

S12. Ans.(a)

S13. Ans.(d)

S14. Ans.(d)

S15. Ans.(e)

Solutions (16-20):

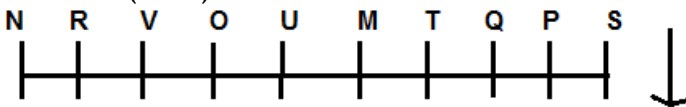

S16. Ans.(c)

S17. Ans.(e)

S18. Ans.(b)

S19. Ans.(a)

S20. Ans.(d)

Solutions (21-25):

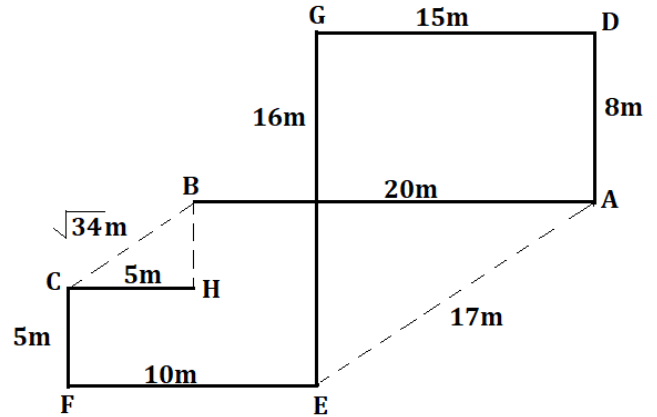

S21. Ans.(c)

S22. Ans.(a)

S23. Ans.(e)

S24. Ans.(b)

S25. Ans.(e)

Solutions (26-27):

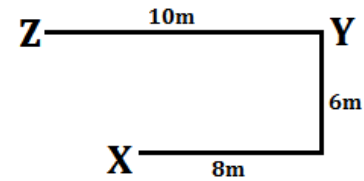

S26. Ans.(b)

S27. Ans.(b)

Solutions (28-29):

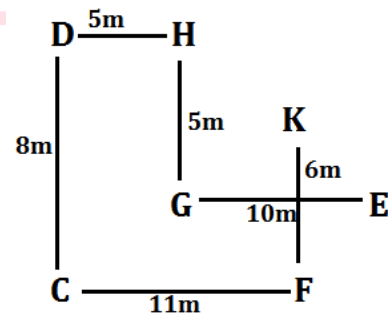

S28. Ans.(c)

S29. Ans.(a)

S30. Ans.(d)

Sol. $Q > R > S > P > T$

S31. Ans.(d)

Sol.

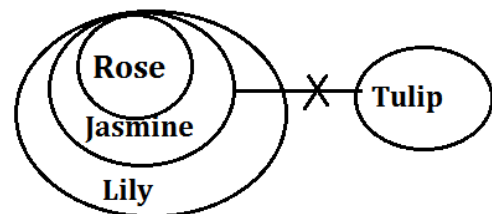

S32. Ans.(a)
Sol.

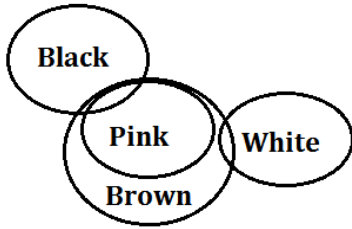

S33. Ans.(b)
Sol.

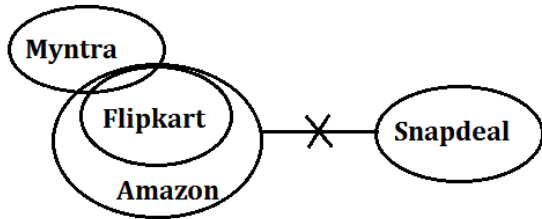

S34. Ans.(b)
Sol.

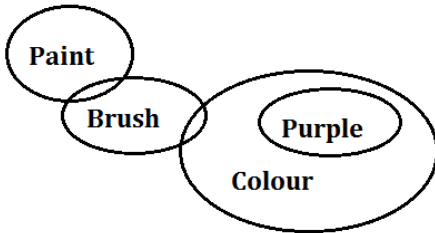

S35. Ans.(c)
Sol.

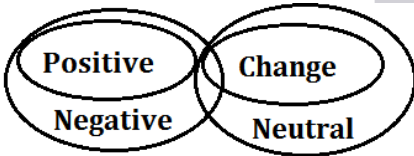

S36. Ans.(c)
Sol.

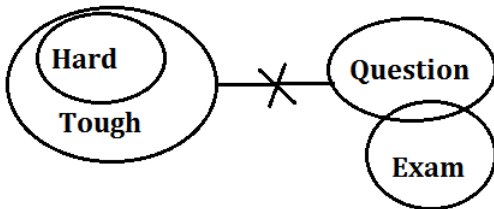

S37. Ans.(b)
Sol.

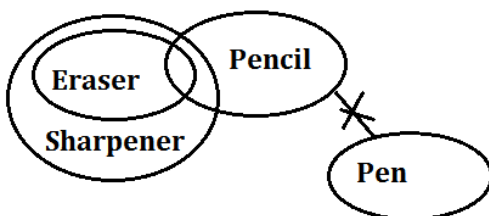

S38. Ans.(e)
Sol.

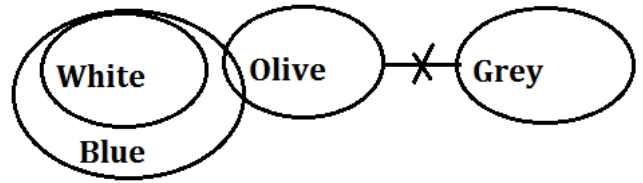

S39. Ans.(c)
Sol.

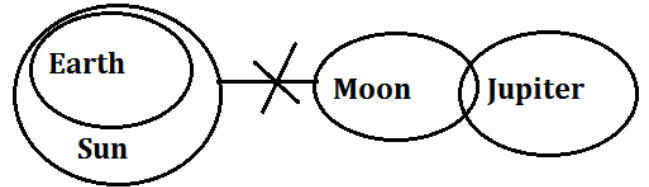

S40. Ans.(d)
Sol.

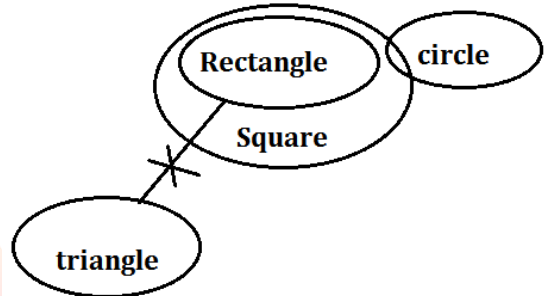

Solutions (41-43):

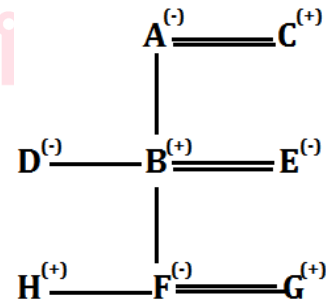

S41. Ans.(a)
S43. Ans.(d)

S42. Ans.(d)

Solutions (44-46):

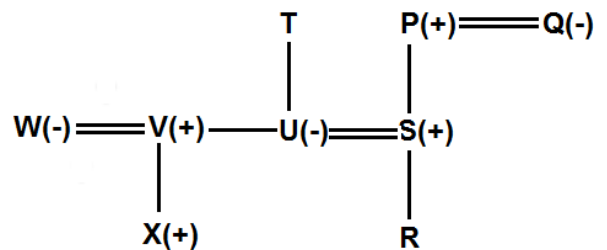

S44. Ans.(e)
S46. Ans.(b)

S45. Ans.(c)

Solutions (47-48):

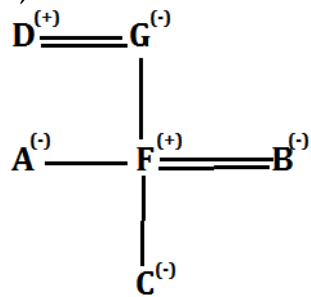

- S47. Ans.(a)
S48. Ans.(b)
S49. Ans.(c)
S50. Ans.(a)

BILINGUAL



RBI ATTENDANT
Live Mock Test
Discussion Batch

Starts Mar 22, 2021 **10 AM to 2 PM**



BOOKS



Visit: publications.adda247.com & store.adda247.com
 For any information, mail us at publications@adda247.com